

- SKELETAL RANGE**
- SHADED POLE**
- 0.5 - 30
WATTS OUTPUT**
- 2 POLE**

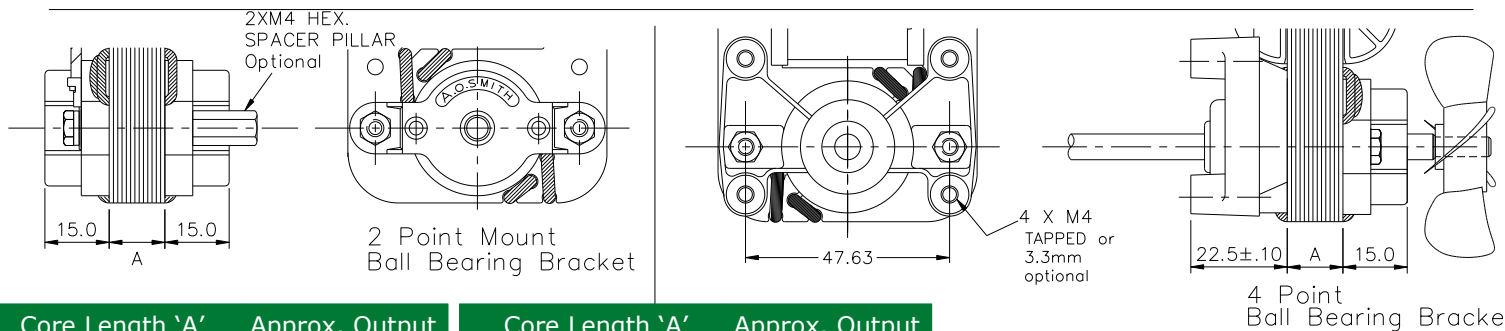
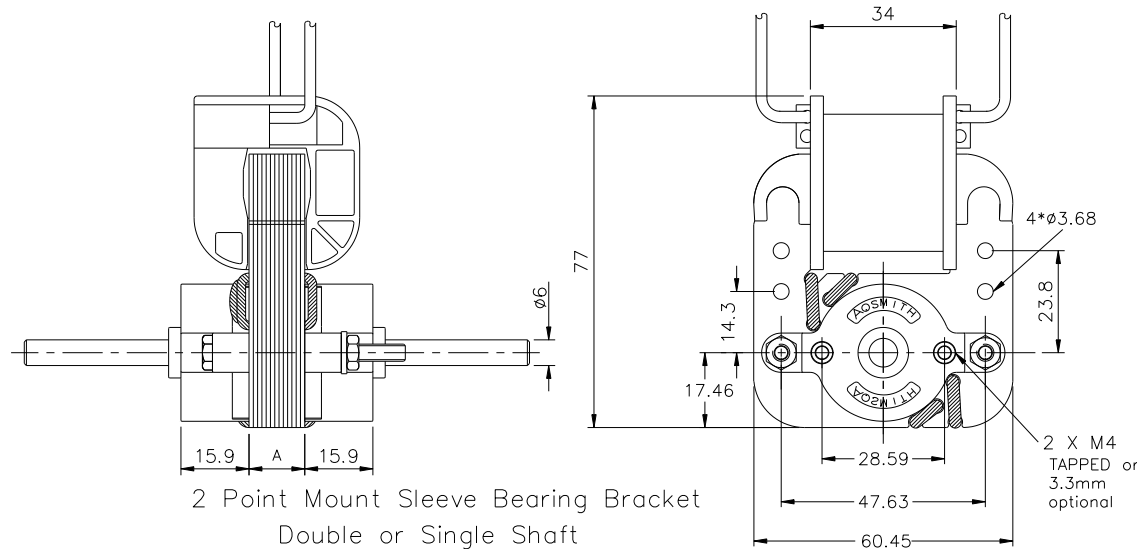

Core Length 'A'		Approx. Output	Core Length 'A'		Approx. Output
12mm	1/2"	3W	32mm	1 1/4"	18W
19mm	3/4"	10W	38mm	1 1/2"	25W
25mm	1"	15W	50mm	2"	30W

Standard Options

SHAFT

- ✓ Single or Double Extension
- ✓ Milled Flat
- ✓ Threaded
- ✓ Maximum 6mm dia.
- ✓ Length to suit spec.

CONSTRUCTION

- ✓ Air over
- ✓ Fan cooled

LEADS

- ✓ Colours & Length to suit spec.
- ✓ Ground Lead (if required).
- ✓ Bare strip, tinned or terminals.

VOLTAGE & FREQUENCY

- ✓ To suit spec (max. 240V 50/60HZ)
- ✓ Dual voltage (optional)

BEARINGS

- ✓ Sleeve (2 point mounting)
- ✓ Ball race (2 or 4 point mounting)
- ✓ M4 Hexagonal Spacers (optional)

SPECIAL

- ✓ Multi-speed (maximum 3)

A.O.Smith Electrical Products Ltd
Heapham Road Industrial Estate
Gainsborough, Lincs. DN21 1XU

<http://www.aosmithepc.co.uk>
sales@aosmithepc.co.uk
Phone: +44(0)1427 614141
Fax: +44(0)1427 617513